

60cm (24") Freezer Column Panel Ready

Dimensions



FRZ605UBLPTT (left hinge)
FRZ605UBRPTT (right hinge)

SIDE VIEW

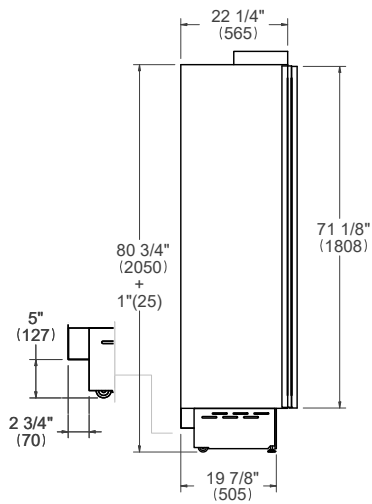

FRONT VIEW

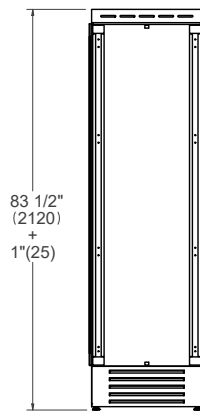

TOP VIEW

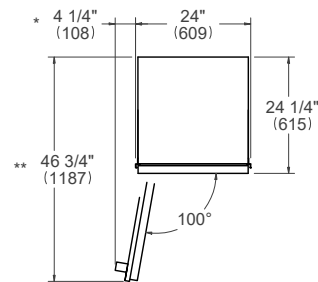

SIDE VIEW

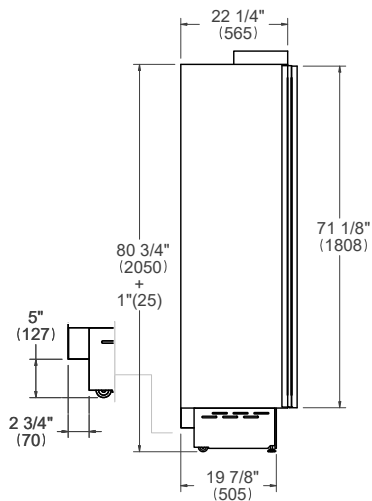

FRONT VIEW

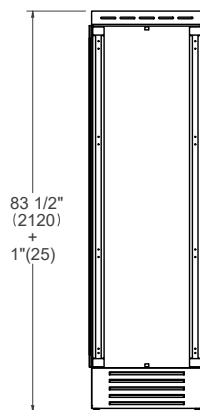

TOP VIEW

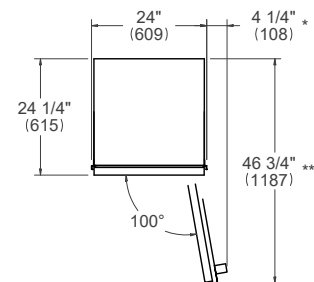

* Maximum Overall Handle Dimension
** Width of 19mm (3/4") Door Panel
For detailed handle dimensions see page 71

Dimensions in parentheses are millimeters unless otherwise specified.

60cm (24") Freezer Column Panel Ready

Installation requirements



INSTALLATION

All Bertazzoni columns can be installed in a standard 635mm (25") depth cutout.

Finish the edges of the opening because they may be visible when the door is open.

For a built-in installation, to cover gaps between the appliance and the adjacent cabinets, special side profiles are factory-installed and covering frames are provided with the product.

For panel ready columns, do not exceed the maximum weight of 34 kg (75 pounds) for door panel. Panel can have thickness ranging between 19mm (3/4") and 28mm (1 1/8").

For instructions of product combinations please see the Multiple Installation Section (page 58).

CABINET REQUIREMENT

Installation of the appliance must be performed in accordance with the provisions of applicable legislation.

Be sure that support of this appliance is perpendicular to the front facing of the wall or cabinet before you perform the installation.

The floor must be flat and must be capable of supporting the weight of the appliance when in use.

| | |
|-------------------------------|-----------------|
| Required floor support | 450 kg (992 lb) |
|-------------------------------|-----------------|

ELECTRICAL REQUIREMENT

The installation must comply with all applicable electrical codes. A properly - grounded horizontally - mounted electrical receptacle should be installed.

Place the electrical supply flush with the back wall and within the shaded area shown in the illustrations.

Placement within the opening may require additional cabinet depth.

For detailed installation specifications consult the multiple installation requirements page or each single product installation manual.

TOP VIEW

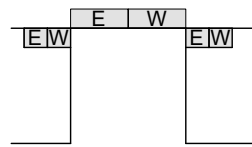

FRONT VIEW

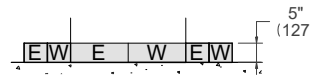

A separate circuit breaker servicing only this appliance is recommended.

| | |
|--------------------------|--|
| Electrical supply | 220-240 V 50/60 Hz 275 W 1,5 Amp |
| Service | 10 Amp dedicated circuit |
| Power Connection | 2-pole 220V SCHUKO plug with 2m power cord |

PLUMBING REQUIREMENTS

Bertazzoni Freezer Columns are provided with a water filter assembly which must be mounted outside the unit.

The appliance must be connected only to a potable water supply system.

To connect to water supply system (for appliances equipped with ice maker) a 6,4mm (1/4") waterline with accessible shut-off valve must be supplied.

The solenoid connection on the appliance is 19mm (3/4") diameter but is metric threaded (NPT).

The system pressure must be between from 8 PSI to 75 PSI (between 0.5 bar and 5 bar). Different pressures can cause malfunctions or leaks in the water system.

For information on how to purchase the water filter, please see Use and Maintenance Manual.

Dimensions in parentheses are millimeters unless otherwise specified.

60cm (24") Freezer Column Panel Ready

Flush installation



TOP VIEW^b

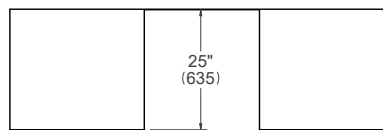

SIDE VIEW

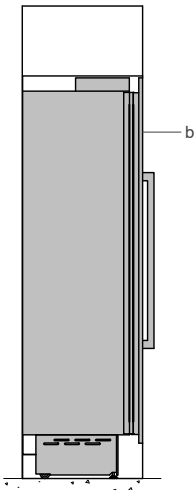

FRONT VIEW

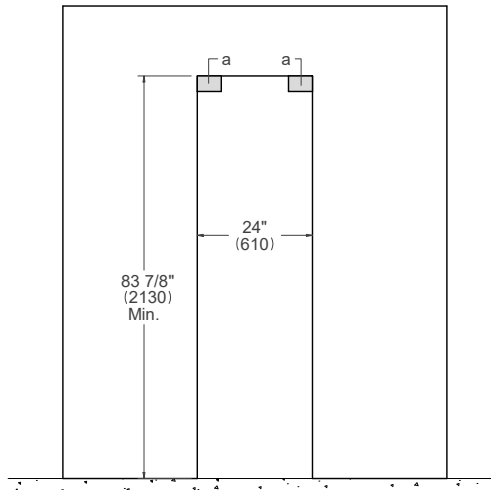

- (a) Area to be left clear for the anti-tipping brackets – 82x127mm (3"1/2x5")
- (b) Panel dimensions available on Built-in Food Preservation Design Guide or Installation Manual

Dimensions in parentheses are millimeters unless otherwise specified.

b: depth includes kitchen cabinet front panel.